



BTM
ADVANCED TECHNOLOGY BANDSAWS

 **SEMIAUTOMATICHE TAGLIO FISSO**
LINEA AP
SEMIAUTOMATIC FIX CUT
AP LINE



SEGATRICI SEMIAUTOMATICHE A DUE MONTANTI TAGLIO FISSO 90°

SEMI-AUTOMATIC TWIN-COLUMN BANDSAW MACHINES 90° FIX CUTTING



Altezza piano di lavoro
Working height
870 mm



kg
900
1550
1850

Mod. **AP 350 SA F**

Mod. **AP 450 SA F**

Mod. **AP 500 SA F**

		Mod. AP 350 SA F	Mod. AP 450 SA F	Mod. AP 500 SA F
		90°	90°	90°
CAPACITÀ TAGLIO Cutting capacities mm		350	450	500
		350	440	480
		400 x 350	510 x 440	510 x 480
Taglio fascio idraulico optional Hydraulic bundle clamping device	BASIC	400 x 185	510 x 230	510 x 250
	MAX	400 x 350	510 x 440	510 x 480
Dimensioni lama Blade dimensions		4000 x 34 x 1,1 mm	4580 x 34 x 1,1 mm	5300 x 41 x 1,3 mm
Potenza motore lama Blade motor power		2,2 kW	2,2 kW	3 kW
Potenza motore pompa refrigerante Cooling pump motor power		0,12 kW	0,12 kW	0,12 kW
Potenza motore pompa idraulica Hydraulic pump motor power		0,37 kW	0,37 kW	0,55 kW
Potenza motore evacuatore trucioli Chip conveyor motor power		0,09 kW	0,09 kW	0,09 kW
Velocità lama Blade speed		20 ÷ 100 m/min	20 ÷ 100 m/min	21 ÷ 100 m/min
Discesa lavoro Cutting downfeed		0 ÷ 200 mm/min	0 ÷ 200 mm/min	0 ÷ 200 mm/min

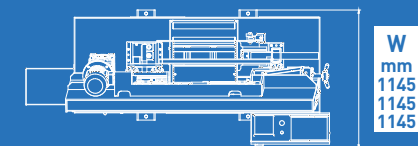
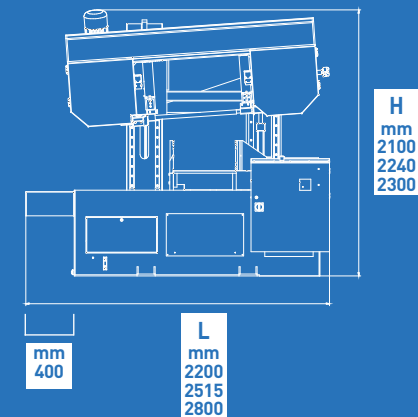

Segatrici a nastro semiautomatiche a due montanti ad alte prestazioni di lavoro.

Twin-column semiautomatic bandsaw machines, for high working performance.

Caratteristiche tecniche

- Arco, basamento e colonne in struttura d'acciaio saldata
- Discesa verticale arco su doppie guide a ricircolo di sfere
- Arco inclinato di 2°
- Tensionamento lama idraulico
- Gruppo riduttore composto da ingranaggi temprati e lubrificati
- Centralina oleodinamica a bassa rumorosità con portata variabile
- Spazzola puliscilama
- Variatore elettronico velocità lama
- Evacuatore trucioli
- Impianto elettrico in bassa tensione secondo normative CE

Technical features

- Bow, base and columns made in welded steel structure
- Vertical bow descent on double ball bearing guides
- 2° tilted bow
- Hydraulic blade tensioning
- Reducer unit with hardened and ground gears
- Low noise hydraulic system with variable flow
- Cleaning brush
- Inverter
- Chip conveyor
- Low voltage electrical system according to EC rules

Tensionamento lama idraulico
Hydraulic blade tensioning

Evacuatore trucioli
Chip conveyor

Pannello comandi
Control panel
Plc
Touch 7"
Touch 10"

AP 450 SA F

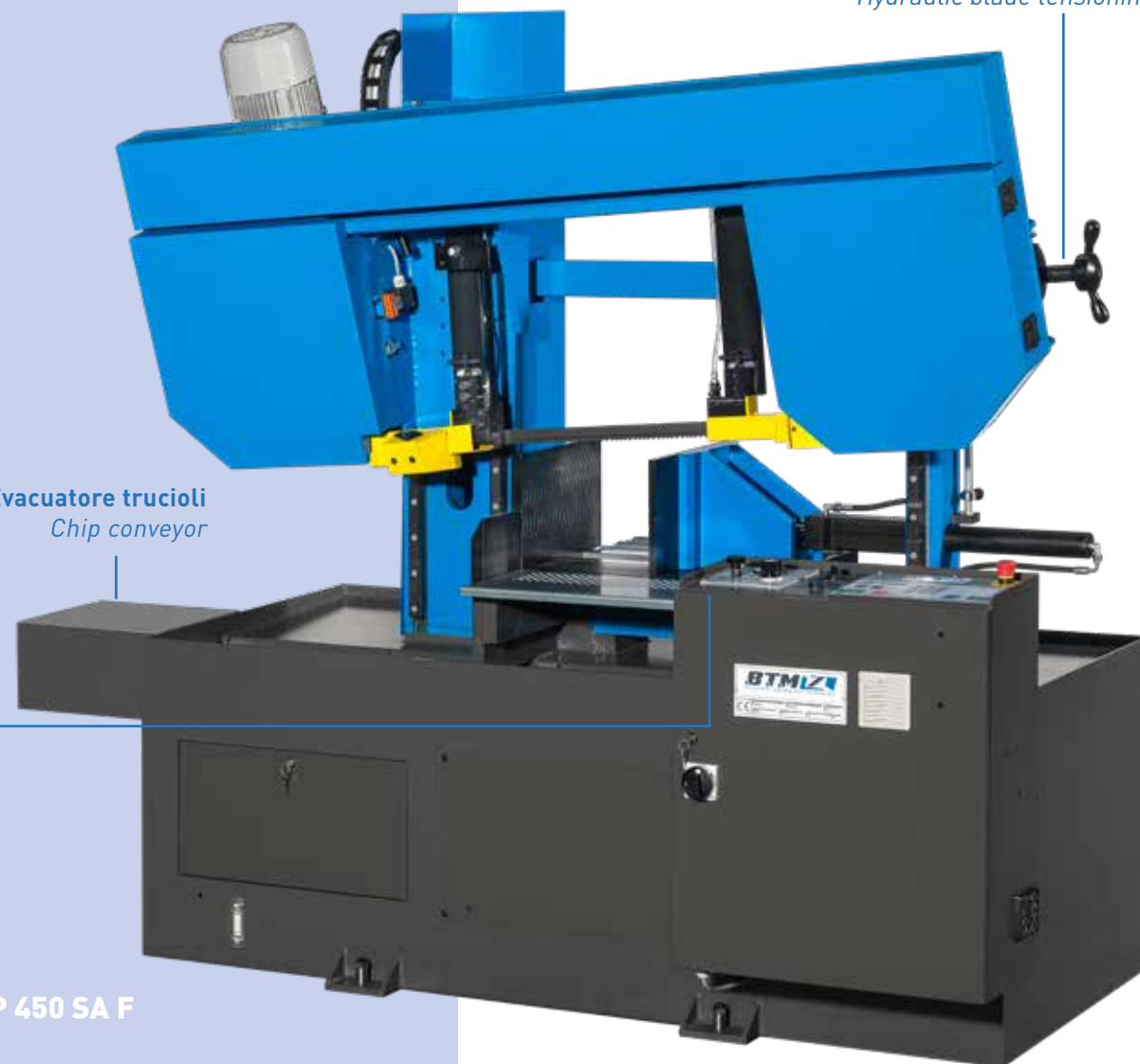

SEGATRICI SEMIAUTOMATICHE A DUE MONTANTI TAGLIO FISSO 90°

SEMAUTOMATIC TWIN-COLUMN BANDSAW MACHINES 90° FIX CUTTING



Altezza piano di lavoro
Working height
870 mm



kg
2200
2700
2800

Mod. **AP 7.5 SA F**

Mod. **AP 7.6 SA F**

Mod. **AP 7.7 SA F**

		90°	90°	90°
CAPACITÀ TAGLIO Cutting capacities mm		510	610	710
		510	610	710
		710 x 510	710 x 610	710 x 710
Taglio fascio idraulico optional Hydraulic bundle clamping device	BASIC	710 x 265	710 x 315	710 x 365
	MAX	710 x 510	710 x 610	710 x 710
Dimensioni lama Blade dimensions		5800 x 41 x 1,3 mm	6740 x 54 x 1,6 mm	7450 x 54 x 1,6 mm
Potenza motore lama Blade motor power		4 kW	5,5 kW	5,5 kW
Potenza motore pompa refrigerante Cooling pump motor power		0,12 kW	0,12 kW	0,4 kW
Potenza motore pompa idraulica Hydraulic pump motor power		0,75 kW	1,5 kW	1,5 kW
Potenza motore evacuatore trucioli Chip conveyor motor power		0,09 kW	0,09 kW	0,09 kW
Velocità lama Blade speed		20 ÷ 100 m/min	20 ÷ 100 m/min	20 ÷ 100 m/min
Discesa lavoro Cutting downfeed		0 ÷ 200 mm/min	0 ÷ 200 mm/min	0 ÷ 200 mm/min

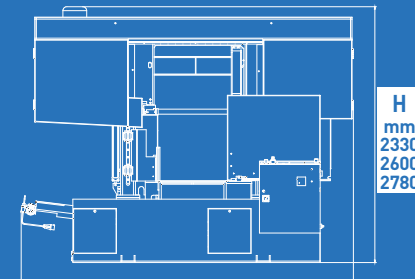

H
mm
2330
2600
2780

L
mm
3330
3470
3570

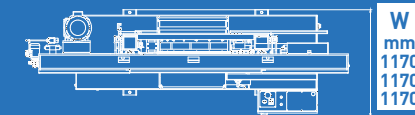

W
mm
1170
1170
1170



Segatrici a nastro semiautomatiche a due montanti ad alte prestazioni di lavoro.

Twin-column semiautomatic bandsaw machines, for high working performance.

Caratteristiche tecniche

- Arco, basamento e colonne in struttura d'acciaio saldata
- Discesa verticale arco su guide a ricircolo di sfere
- Tensionamento lama idraulico
- Gruppo riduttore composto da ingranaggi temprati e lubrificati
- Centralina oleodinamica a bassa rumorosità con portata variabile
- Spazzola puliscilama
- Variatore elettronico velocità lama
- Evacuatore trucioli
- Impianto elettrico in bassa tensione secondo normative CE

Technical features

- Bow, base and columns made in welded steel structure
- Vertical bow descent on ball bearing guides
- Hydraulic blade tensioning
- Reducer unit with hardened and ground gears
- Low noise hydraulic system with variable flow
- Cleaning brush
- Inverter
- Chip conveyor
- Low voltage electrical system according to EC rules

Tensionamento lama idraulico
Hydraulic blade tensioning



SEGATRICI SEMIAUTOMATICHE A DUE MONTANTI TAGLIO FISSO 90°

SEMAUTOMATIC TWIN-COLUMN BANDSAW MACHINES 90° FIX CUTTING



Altezza piano di lavoro
Working height
630 mm



kg
3200
5500
12600

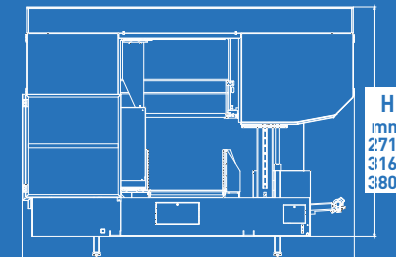

L
mm
4070
4520
5200

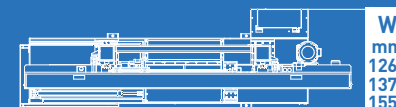

Mod. **AP 8.8 SA F**

Mod. **AP 10.1 SA F**

Mod. **AP 12.5 SA F**

		90°	90°	90°
CAPACITÀ TAGLIO Cutting capacities mm		810	1010	1250
		810	1010	1250
		810 x 810	1010 x 1010	1250 x 1250
Taglio fascio idraulico optional Hydraulic bundle clamping device	BASIC	810 x 415	1010 x 515	1250 x 635
	MAX	810 x 810	1010 x 1010	1250 x 1250
Dimensioni lama Blade dimensions		8900 x 54 x 1,6 mm	9955 x 67 x 1,6 mm	12500 x 67 x 1,6 mm
Potenza motore lama Blade motor power		5,5 kW	5,5 kW	7,5 kW
Potenza motore pompa refrigerante Cooling pump motor power		0,4 kW	0,4 kW	0,4 kW
Potenza motore pompa idraulica Hydraulic pump motor power		1,5 kW	2,2 kW	2,2 kW
Potenza motore evacuatore trucioli Chip conveyor motor power		0,09 kW	0,25kW	2 x 0,25 kW
Velocità lama Blade speed		20 ÷ 100 m/min	20 ÷ 100 m/min	20 ÷ 100 m/min
Discesa lavoro Cutting downfeed		0 ÷ 200 mm/min	0 ÷ 200 mm/min	0 ÷ 200 mm/min



Segatrici a nastro semiautomatiche a due montanti in esecuzione pesante ad alte prestazioni di lavoro.

Twin-column semiautomatic bandsaw machines, heavy construction for high working performance.

Caratteristiche tecniche

- Arco, basamento e colonne in struttura d'acciaio saldata
- Discesa verticale arco su guide a ricircolo di sfere
- Tensionamento lama idraulico
- Gruppo riduttore composto da ingranaggi temprati e lubrificati
- Centralina oleodinamica a bassa rumorosità con portata variabile
- Spazzola puliscilama
- Variatore elettronico velocità lama
- Evacuatore trucioli
- Impianto elettrico in bassa tensione secondo normative CE

Technical features

- Bow, base and columns made in welded steel structure
- Vertical bow descent on ball bearing guides
- Hydraulic blade tensioning
- Reducer unit with hardened and ground gears
- Low noise hydraulic system with variable flow
- Cleaning brush
- Inverter
- Chip conveyor
- Low voltage electrical system according to EC rules

Pannello comandi
Control panel
Touch 7"
Touch 10"



Evacuatore trucioli
Chip conveyor

AP 10.1 SA F

ACCESSORI E RULLIERE

Optional accessories and roller tracks



- Rullo motorizzato
- Rullo motorizzato zigrinato temprato
- Allineatore
- Regolatore pressione morsa
- Dispositivo controllo ottico posizione lama (laser)
- Dispositivo controllo deviazione lama (standard su versione TOUCH)
- Dispositivo taglio a secco
- Taglio in fascio idraulico BASIC
- Taglio in fascio idraulico MAX (con prolunga morse)
- Dispositivo rotazione arco automatica
- Industry 4.0 (solo per TOUCH)
- Teleassistenza (solo per TOUCH)

- *Powered roller*
- *Powered roller knurled tempered*
- *Piece aligner*
- *Adjustable vice pressure*
- *Blade position optical control device (laser)*
- *Blade deflection control device (standard on TOUCH version)*
- *Dry cooling device*
- *Hydraulic bundle clamping device BASIC*
- *Hydraulic bundle clamping device MAX (with vice jaws extension)*
- *Bow mitre rotation device*
- *Industry 4.0 (only for TOUCH)*
- *Teleservice (only for TOUCH)*



RIS-01
Riscontro meccanico con scorrimento su profilo in acciaio e sollevamento manuale

Mechanical length stop with sliding on iron pipe and manual lifting

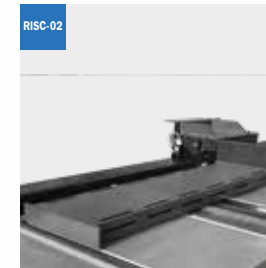

RIS-02
Riscontro motorizzato con scorrimento su profilo in acciaio con encoder e sollevamento pneumatico

Powered length stop with sliding on iron pipe with encoder and pneumatic lifting

Allineatore
Piece aligner

Rullo motorizzato
Powered roller track



1.200 kg/m

RULLIERA IN INGRESSO

Portata: 1.200 kg/m.
Con vasca raccogli acqua.
Disponibile in moduli da 1 a 6 metri. Lunghezze differenti a richiesta.
Passo rulli disponibile: 450/250/125 mm.

INFEED ROLLER TRACK

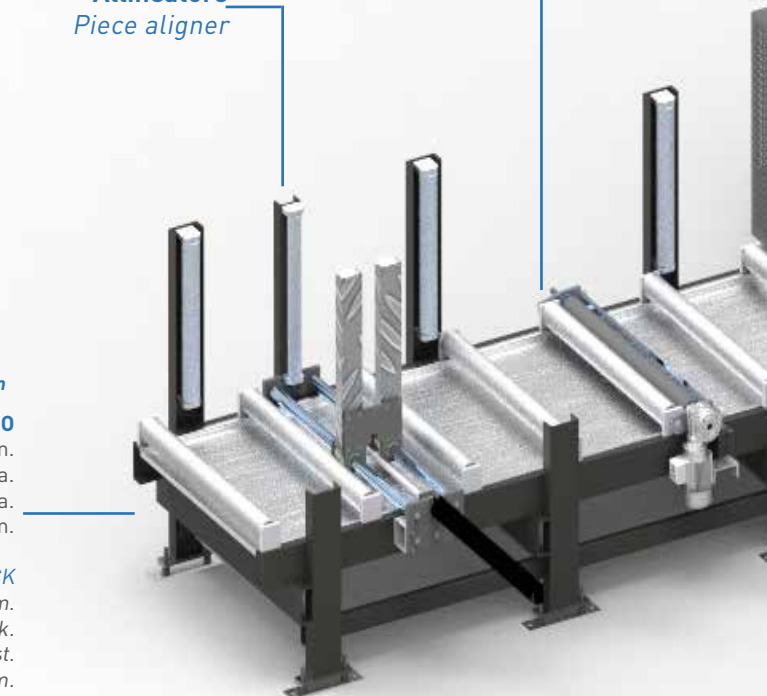
Carrying capacity : 1.200 Kg/m.
With water collection tank.
Available in modules from 1 to 6 m long. Different lengths on request.
Available roller pitch : 450/250/125 mm.



Mod AP 10.1 SA F

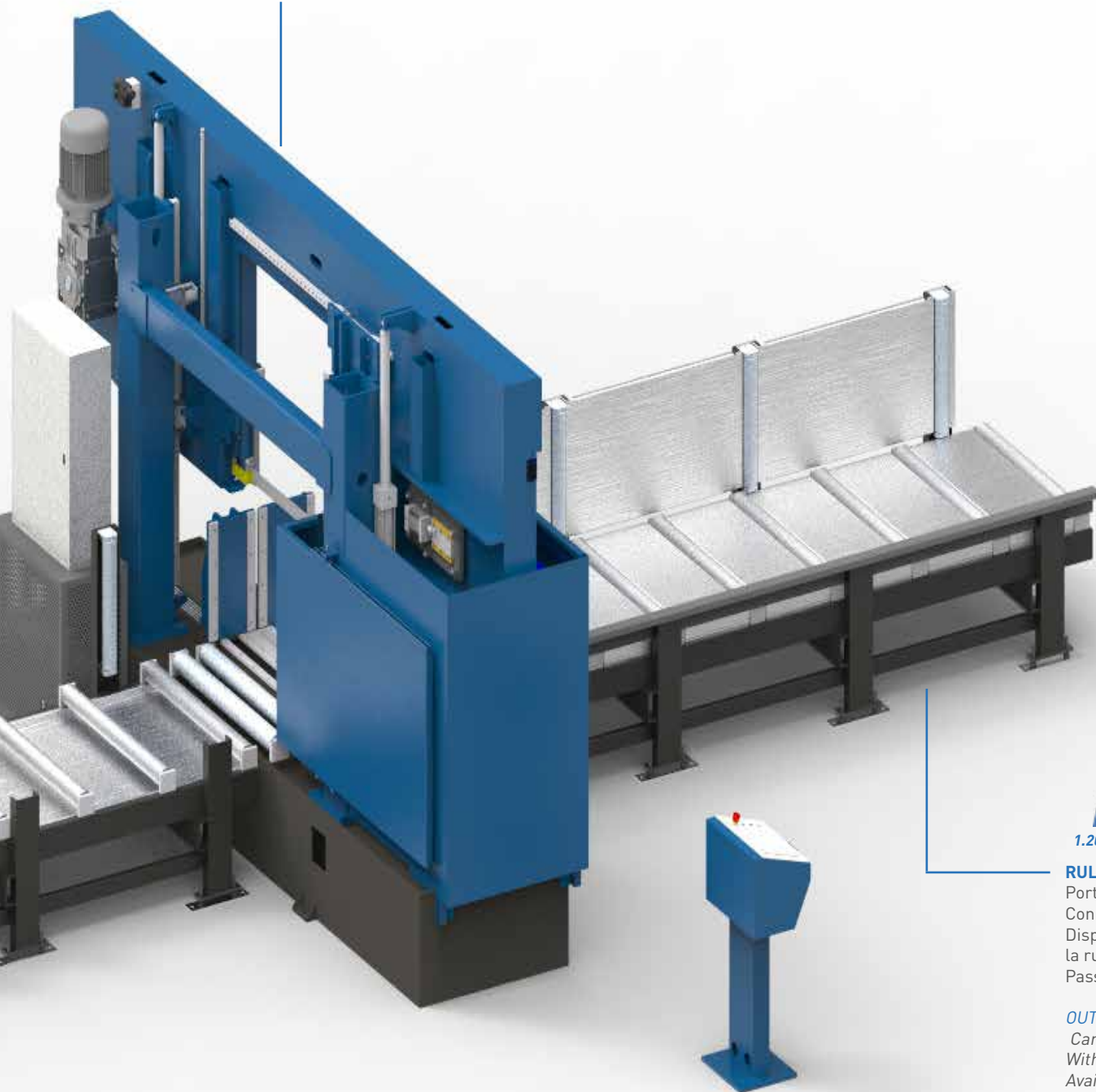

1.200 kg/m

RULLIERA IN USCITA

Portata: 1.200 kg/m.
Con sponde anticaduta e vasca raccogli acqua.
Disponibile in moduli da 1 a 6 m. Lunghezze differenti a richiesta.
la rulliera può essere aperta o chiusa con pianetti asportabili.
Passo rulli disponibile: 450/250/125 mm.

OUTFEED ROLLER TRACK

Carrying capacity : 1.200 Kg/m.
With safety edge and water collection tank.
Available in modules from 1 to 6 m long. Different lengths on request.
The roller track can be open or closed with removable plates between rollers.
Available roller pitch : 450/250/125 mm.

LE NOSTRE SOLUZIONI SU RICHIESTA SPECIFICA DEL CLIENTE
OUR CUSTOM MADE SYSTEMS CLOSE TO THE NEEDS OF OUR CUSTOMERS



1600 X 230 SA Touch Segatrice a nastro semiautomatica in esecuzione pesante, ad alte prestazioni di lavoro, ideale per il taglio di ogni tipo di materiale compresi i metalli ad altissima resistenza e durezza (ad es. titanio, hastelloy, inconel).

1600 X 230 SA Touch *Semiautomatic bandsaw machine at high working performances, ideal for cutting any type of material including strong and hard metals like titanium, hastelloy, inconel.*



AP 8.8 SA F impianto per taglio bobine di carta Ø 800
AP 8.8 SA F *paper coils Ø 800 cutting system*



TT 350 segatrice speciale per taglio tondini
TT 350 segatrice speciale per taglio tondini

Since 1982



Btm srl Unipersonale
Via F.lli Kennedy, 8
24060 Carobbio degli Angeli
Bergamo (Italy)

Tel. +39 035 4251125

info@btm.it
www.btm.it



facchinetti@forlani.com 03/21

BTM fin dai primi anni '80 è leader nella progettazione e realizzazione di segatrici a nastro speciali e di grandi dimensioni per soddisfare i clienti che hanno esigenze particolari e sono alla ricerca di un prodotto affidabile, sicuro e personalizzato.

Il prodotto finale è il risultato di un progetto frutto della collaborazione tra BTM ed il cliente.

La progettazione, la produzione, l'assemblaggio ed il collaudo delle macchine sono eseguiti totalmente all'interno di BTM da personale altamente specializzato, nel pieno rispetto della filosofia MADE IN ITALY.

BTM since the early 80s is the leader in the design and production of special and oversized bandsaw machines, to satisfy the special needs of the customers who want a reliable, safe and custom-made product.

The final result is a custom machine developed by the close co-operation between BTM and its customers. The design engineering, production, assembly, and the final machine testing are all performed by highly skilled personnel at btm's plants, following the "MADE IN ITALY" philosophy.

La Btm Srl si riserva la facoltà di modificare il presente catalogo senza alcun preavviso. Le immagini e i dati nel presente catalogo sono da considerarsi puramente indicativi. Btm Srl reserves the right at any time and without advance notice to introduce modifications to the present catalogue. The images and data in this catalogue must be considered for you for reference only.